

ROASTER COMBI DU-GP2GC-R76



AVAILABLE COLORS



ACCESSORIES

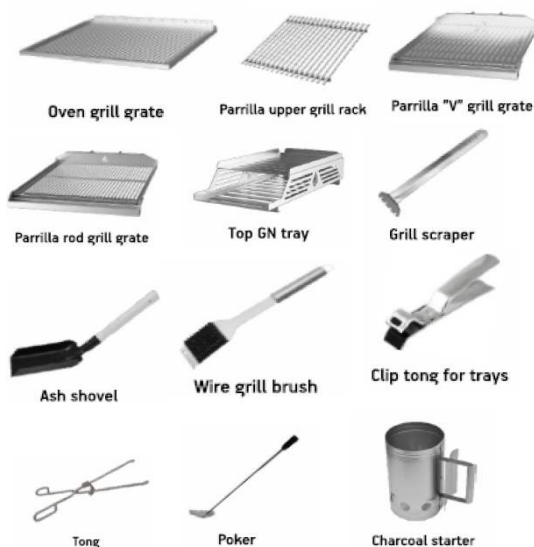

CABINET OPTIONS



TECHNICAL INFORMATION

Productivity	± 175 Diners
Fire up time	30 min average
Charcoal daily consumption*	Charcoal 33 – 39 kg
Broiling temperature	250°C to 350°C
Exhaust rate	5.000 m3/h

DIMENSIONS & WEIGHTS

Dimensions (NET)	2255X825X1645 mm
Weight (NET)	680 kg

INSTALLATION

Clearance with non-flammable equipment	100 mm
Clearance with flammable equipment	300 mm
* Depends on the charcoal quality	

INCLUDED

Scraper	2X Parrilla "V" grill grates	Ash Collector Drawer	Grease Collector	Fire Bricks
Poker	3X Upper Grill Racks	Charcoal Shovel	Charcoal Starter	Packaging
Tong	2X Oven Grill Grates	Fire breaker	Wire Brush	Clip Tong
Thermal Protection	2X Top GN Trays			

TECHNICAL INFORMATION ROC76

Productivity + -	110 diners
Roasting area	735X590 mm
Fire up time	30 min average
Charcoal daily consumption*	Charcoal 15 – 17 kg
Roasting temperature	250 °C to 350 °C
Exhaust rate	2.500 m3/h
Heat Output*	8 kw
Extraction diameter	180 mm
Performance	9h
Dimensions without Packaging	985X825X1645 mm
Dimensions with Packaging	1130X1020X1930 mm
Net Weight	410 kg
Gross Weight	478 kg



TECHNICAL INFORMATION GP2GC

Roasting area	1000X620 mm
Fire up time	30 min average
Charcoal daily consumption*	Charcoal 18 – 22 kg
Grilling temperature	200 °C to 250 °C
Exhaust rate	2.500 m3/h
Dimensions without Packaging	1270X825X1550 mm
Dimensions with Packaging	1420X1020X1790 mm
Net Weight	270 kg
Gross Weight	370 kg



TECHNICAL DRAWINGS

Front view

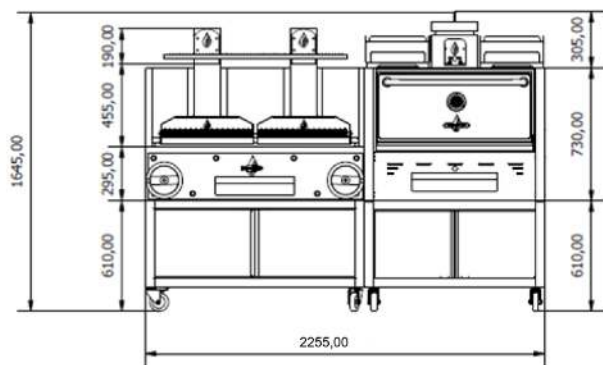

Side view

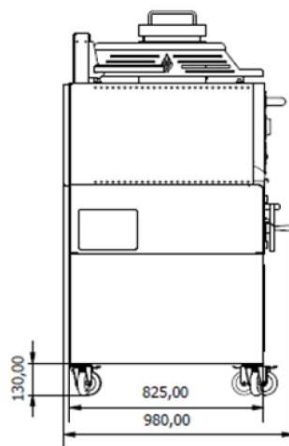

Dimensions with Open Door

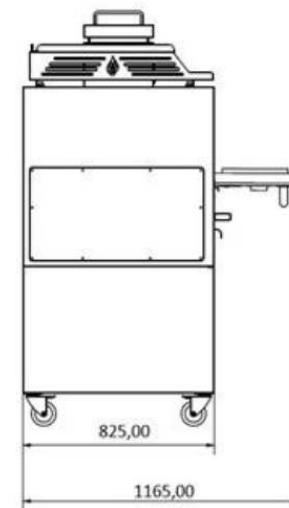

Top view

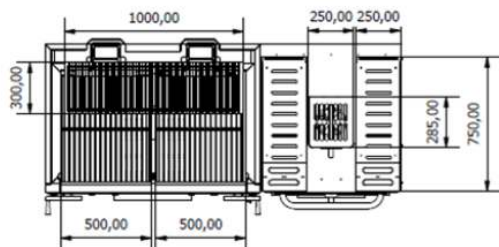

Roasting Area Oven

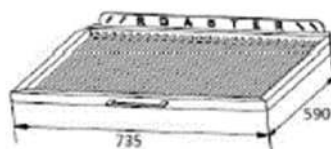

Roasting Area Parrilla

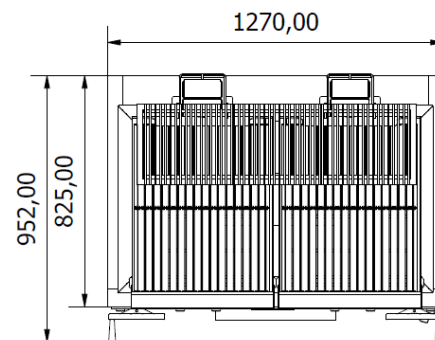

MAIN COMPONENTS

