

**ROASTER PARRILLA F- SERIES
CHARCOAL GRILL GPFB26C**



AVAILABLE COLORS



Black Red Blue Inox

ACCESSORIES

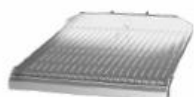

Parrilla "V" grill grate

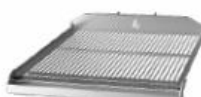

Parrilla rod grill grate



Parrilla upper grill rack



Poker



Grill scraper



Ash shovel



Charcoal starter

OPTIONAL



Open Cabinet with one shelf



Open Cabinet with drawers,
GN supports and one shelf



Cabinet with opening doors
and GN supports



Frontal GN support



Thermal protection

TECHNICAL INFORMATION

Roasting area	2X 630X620 mm
Fire up time	30 min average
Charcoal daily consumption*	Charcoal 35 – 45 kg
Broiling temperature	200 °C to 250 °C
Exhaust rate	5.600 m3/h

DIMENSIONS & WEIGHTS

Without packaging	2350X825X1550 mm
With packaging	2500X1020X1790 mm
Weight (NET)	350 kg
Weight (with packaging)	455 kg

INSTALLATION

Clearance with non-flammable equipment	100 mm
Clearance with flammable equipment	300 mm

*Depends on the charcoal quality

INCLUDED

Scraper	2X Parrilla "V" grill grates	Ash Collector Drawer	Grease Collector	Fire Bricks
Poker	2X Upper Grill Racks	Charcoal Shovel	Charcoal Starter	Packaging

TECHNICAL DRAWINGS

Front view

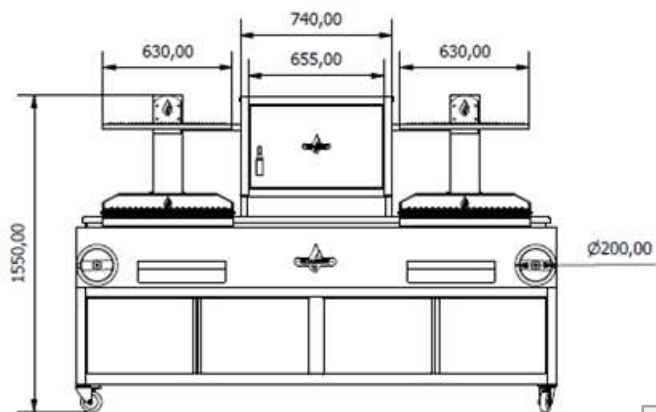

Side view

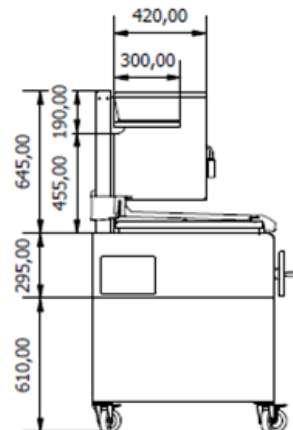

Top view

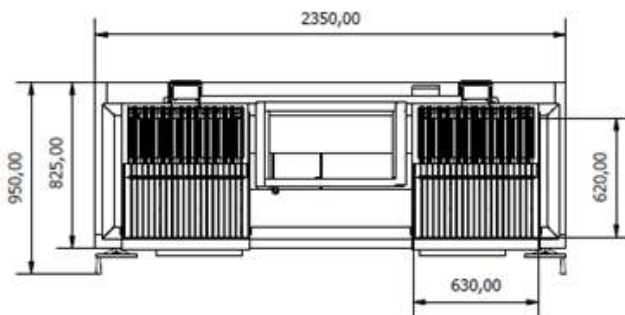

MAIN COMPONENTS

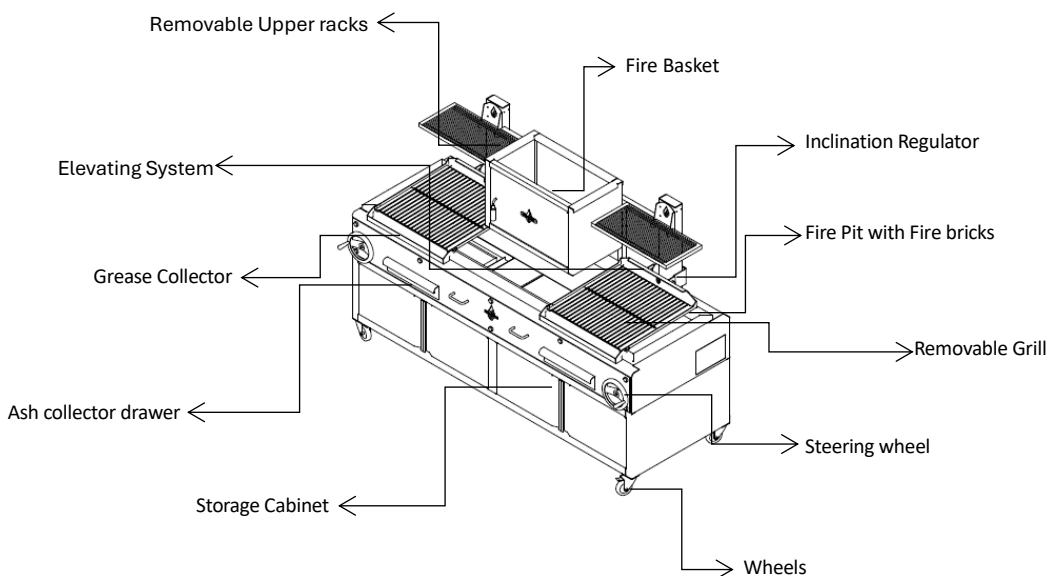

*Dimensions in mm

*The parrilla F- SERIES grills are subject to technical and design changes without previous notice

