

**ROASTER PARRILLA F- SERIES
CHARCOAL GRILL GPFS25**

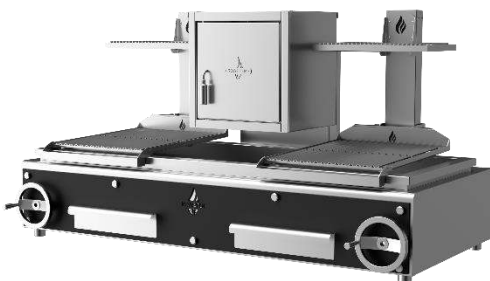

AVAILABLE COLORS



Black Red Blue Inox

ACCESSORIES

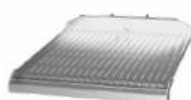

Parrilla "V" grill grate

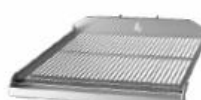

Parrilla rod grill grate



Parrilla upper grill rack



Poker



Grill scraper



Ash shovel



Charcoal starter

OPTIONAL



Frontal GN support



Thermal protection

TECHNICAL INFORMATION

| | |
|-----------------------------|---------------------|
| Roasting area | 2X 500X620 mm |
| Fire up time | 30 min average |
| Charcoal daily consumption* | Charcoal 27 – 35 kg |
| Broiling temperature | 200 °C to 250 °C |
| Exhaust rate | 4.600 m3/h |

DIMENSIONS & WEIGHTS

| | |
|-------------------------|------------------|
| Without packaging | 1850X825X1000 mm |
| With packaging | 2000X1020X1240mm |
| Weight (NET) | 200 kg |
| Weight (with packaging) | 305 kg |

INSTALLATION

| | |
|--|--------|
| Clearance with non-flammable equipment | 100 mm |
| Clearance with flammable equipment | 300 mm |

*Depends on the charcoal quality

INCLUDED

| | | | | |
|---------|------------------------------|----------------------|------------------|-------------|
| Scraper | 2X Parrilla "V" grill grates | Ash Collector Drawer | Grease Collector | Fire Bricks |
| Poker | 2X Upper Grill Racks | Charcoal Shovel | Charcoal Starter | Packaging |



TECHNICAL DRAWINGS

Front view

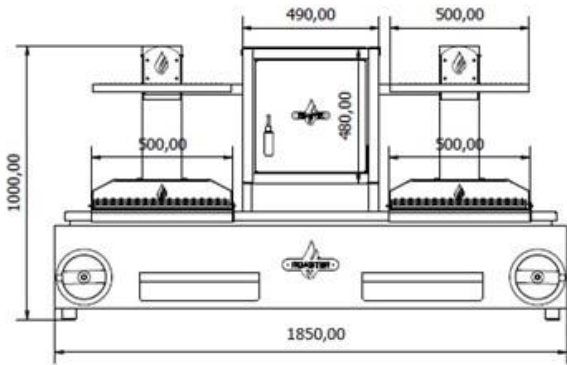

Side view

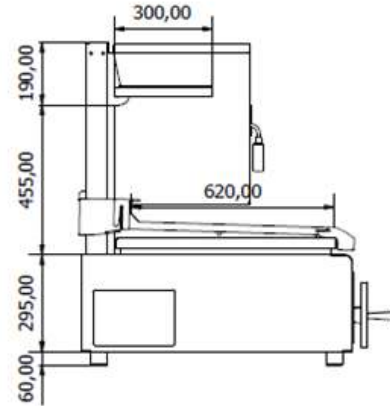

Top view

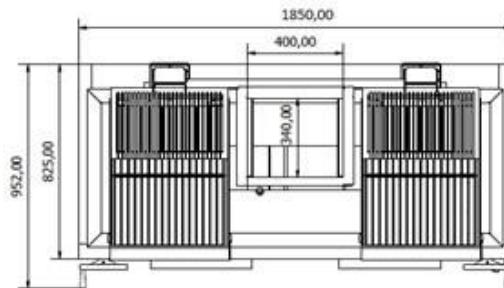

MAIN COMPONENTS

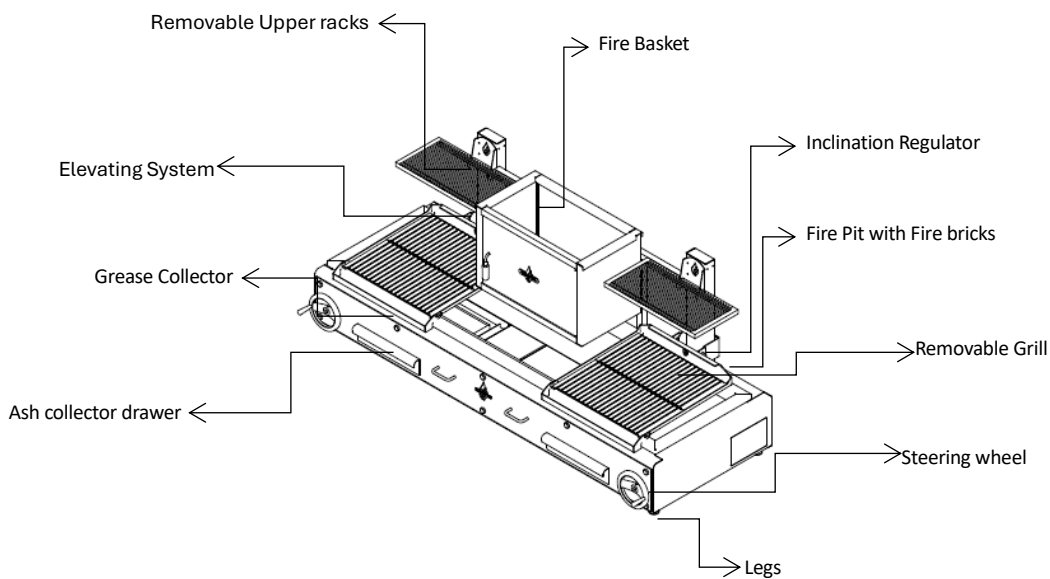

*Dimensions in mm

*The parrilla F- SERIES grills are subject to technical and design changes without previous notice

