

**ROASTER CHARCOAL CHURRASCO GRILL
K12BF**



AVAILABLE COLORS



Black Red Blue Inox

ACCESSORIES

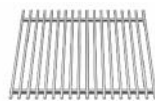

Rod grill grate



Basket



Skewers



Ash shovel



Grill scraper



Poker



Waiting stand



Charcoal starter

TECHNICAL INFORMATION

| | |
|----------------------------------|---------------------------------------|
| Roasting area | 1330X700 mm |
| Maximum capacity | 12 skewers// 4 baskets//4 grill racks |
| Fire up time | 30 min average |
| Charcoal daily consumption* | Charcoal 17 - 25 kg |
| Maximum weight per skewer/basket | 5 – 7 kg |
| Maximum capacity chickens | 12 |
| Exhaust rate | 4.000 m3/h |
| Electric connection | EU:220 V /50 Hz USA:120 V /60 Hz |

DIMENSIONS & WEIGHTS

| | |
|-------------------------|------------------|
| Without packaging | 1600X810X1000 mm |
| With packaging | 1710X910X1310 mm |
| Weight (NET) | 275 kg |
| Weight (with packaging) | 355 kg |

INSTALLATION

| | |
|--|--------|
| Clearance with non-flammable equipment | 100 mm |
| Clearance with flammable equipment | 300 mm |

*Depends on the charcoal quality

INCLUDED

| | | | | |
|-----------------|-------------|------------------|---------------|------------|
| 2X Grill grates | Poker | Charcoal Starter | Grill Scraper | 3X Baskets |
| 6 Skewers 8X8mm | Fire Bricks | Ash shovel | Waiting Stand | Packaging |



TECHNICAL DRAWINGS

Front view

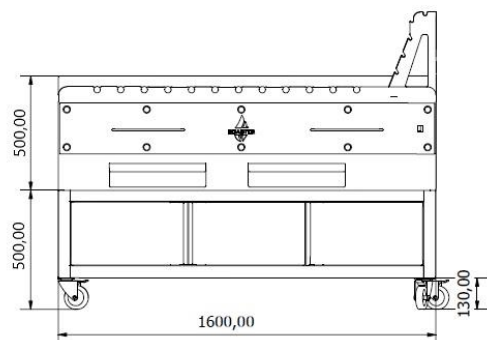

Side View

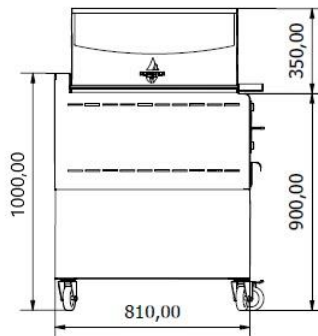

Grill grates

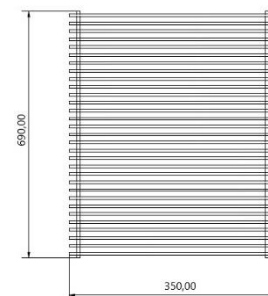

Basket dimension

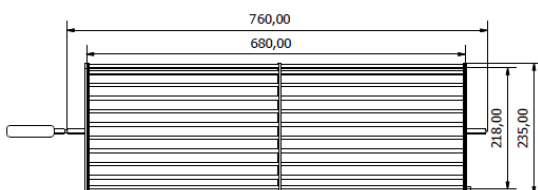

Top view

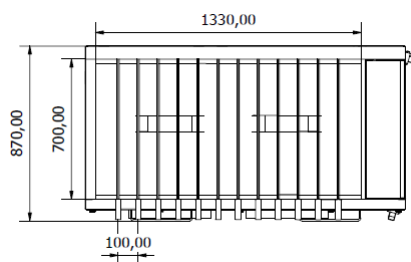

MAIN COMPONENTS

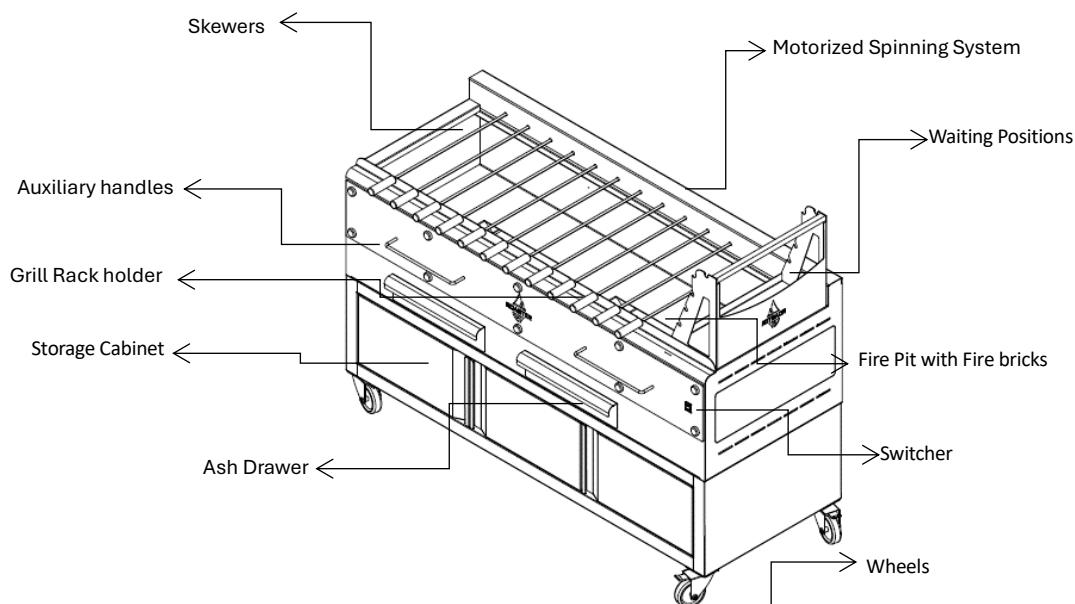

*Dimensions in mm

*The churrasco grills are subject to technical and design changes without previous notice

