

ROASTER MU – GP1GC – R56



AVAILABLE COLORS



ACCESSORIES



CABINET OPTIONS



TECHNICAL INFORMATION

Productivity	± 85 Diners
Fire up time	30 min average
Charcoal daily consumption*	Charcoal 26 – 32 kg
Roasting temperature	250 °C to 350 °C
Exhaust rate	4.100 m3/h

DIMENSIONS & WEIGHTS

Dimensions (NET)	1585X825X1645 mm
Weight (NET)	512 kg

INSTALLATION

Clearance with non-flammable equipment	100 mm
Clearance with flammable equipment	300 mm

INCLUDED

Fire braker	Tong	Grill Scraper	2X Stainless Steel Grill Grates Oven
Clip Tong	Ash Shovel	1X Grill Grate Parrilla	2X Parrilla Upper Grill Rack
Thermal Protection	2x Top GN Trays	Wire Brush	Poker
Grease Collector	Ash Collector Drawer	Charcoal Starter	Packaging

TECHNICAL INFORMATION ROC56

Productivity + -	75 dinners
Roasting area	535X590 mm
Fire up time	30 min average
Charcoal daily consumption*	Charcoal 10 – 12 kg
Roasting temperature	250 °C to 350 °C
Exhaust rate	2.100 m3/h
Heat Output*	6 kw
Extraction diameter	180 mm
Performance*	9h
Dimensions without Packaging	785X825X1645 mm
Dimensions with Packaging	930X1020X1930mm
Net Weight	327 kg
Gross Weight	380 kg



TECHNICAL INFORMATION GP1GC

Roasting area	630X620 mm
Fire up time	30 min average
Charcoal daily consumption*	Charcoal 16 – 20 kg
Grilling temperature	200 °C to 250 °C
Exhaust rate	2.000 m3/h
Dimensions without Packaging	800X825X1550 mm
Dimensions with Packaging	930X1020X1790 mm
Net Weight	185 kg
Gross Weight	261 kg



*Depends on the charcoal quality



TECHNICAL DRAWINGS

Front view

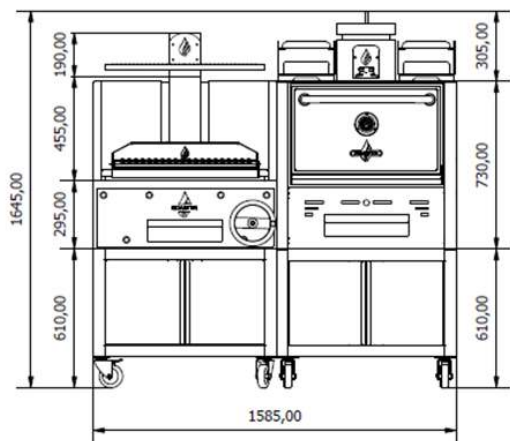

Side view

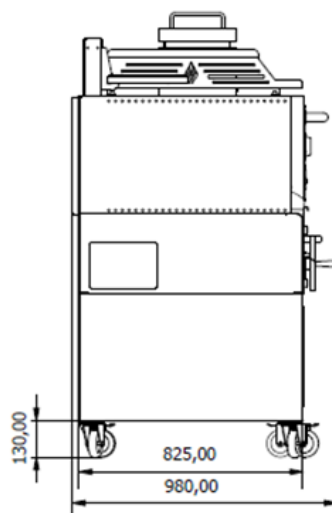

Dimensions with Open Door

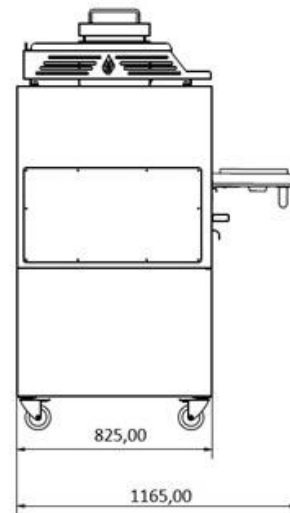

Top view

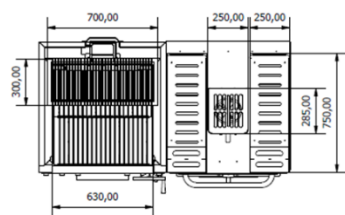

Roasting area Oven

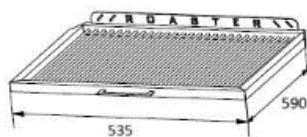

Roasting area Parrilla

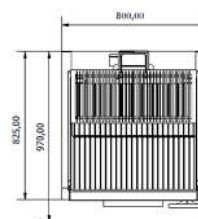

MAIN COMPONENTS

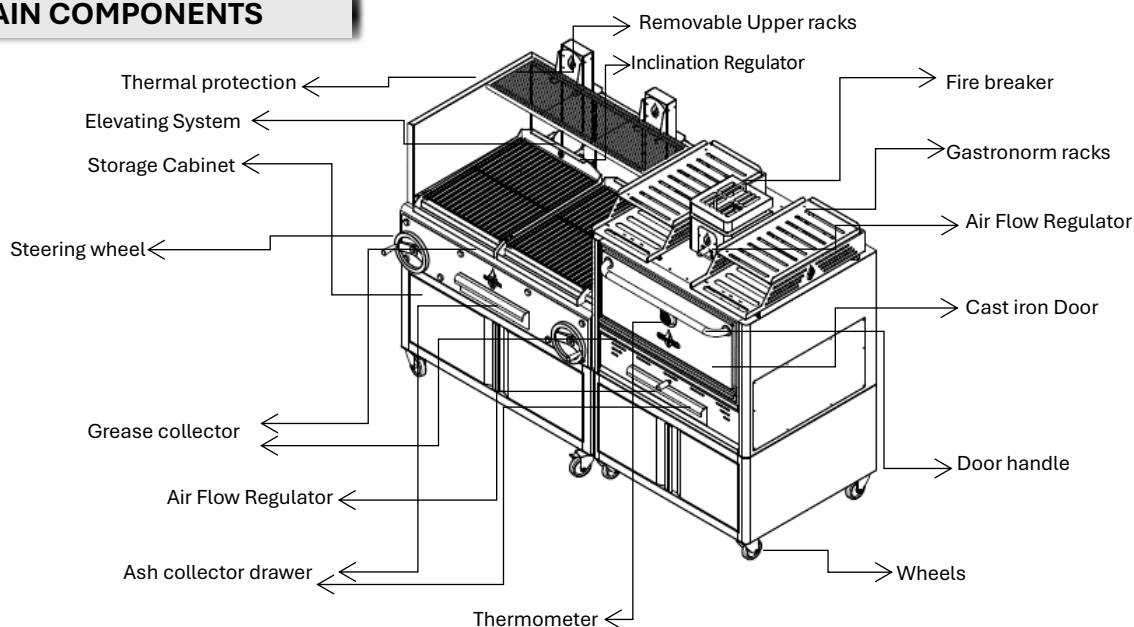

*Dimensions in mm

*The charcoal multi is subject to technical and design changes without previous notice

