

## ROASTER MU – GP2GC – R76



### AVAILABLE COLORS



### ACCESSORIES



### CABINET OPTIONS



### TECHNICAL INFORMATION

Productivity	± 125 Diners
Fire up time	30 min average
Charcoal daily consumption*	Charcoal 33 – 39 kg
Roasting temperature	250 °C to 350 °C
Exhaust rate	5.000 m3/h

### DIMENSIONS & WEIGHTS

Dimensions (NET)	2185X825X1645 mm
Weight (NET)	670 kg

### INSTALLATION

Clearance with non-flammable equipment	100 mm
Clearance with flammable equipment	300 mm

### INCLUDED

Fire braker	Tong	Grill Scraper	2X Stainless Steel Grill Grates Oven
Clip Tong	Ash Shovel	2X Grill Grate Parrilla	3X Parrilla Upper Grill Racks
Thermal Protection	2x Top GN Trays	Wire Brush	Poker
Grease Collector	Ash Collector Drawer	Charcoal Starter	Packaging

### TECHNICAL INFORMATION ROC76

Productivity + -	110 dinners
Roasting area	735X590 mm
Fire up time	30 min average
Charcoal daily consumption*	Charcoal 15 – 17 kg
Roasting temperature	250 °C to 350 °C
Exhaust rate	2.500 m3/h
Heat Output*	8 kw
Extraction diameter	180 mm
Performance*	9h
Dimensions without Packaging	985X825X1645 mm
Dimensions with Packaging	1130X1020X1930 mm
Net Weight	410 kg
Gross Weight	478kg



### TECHNICAL INFORMATION GP2GC

Roasting area	1000X620 mm
Fire up time	30 min average
Charcoal daily consumption*	Charcoal 18 – 22 kg
Grilling temperature	200 °C to 250 °C
Exhaust rate	2.500 m3/h
Dimensions without Packaging	1200X825X1550 mm
Dimensions with Packaging	1350X1020X1790 mm
Net Weight	260 kg
Gross Weight	350 kg



\*Depends on the charcoal quality



**TECHNICAL DRAWINGS**

Front view

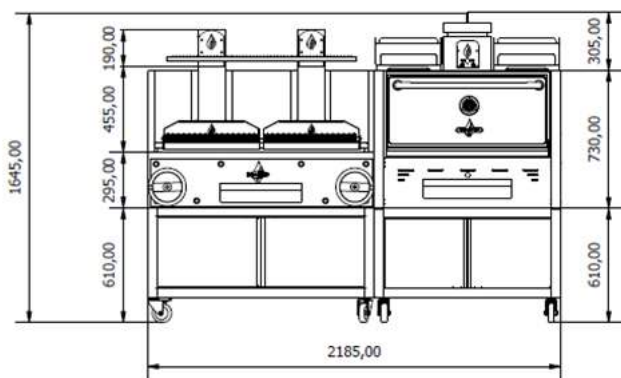

Side view

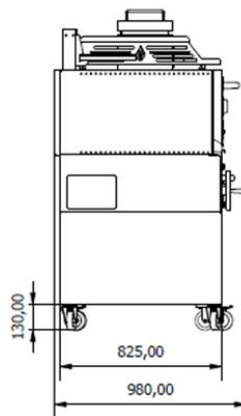

Dimensions with Open Door

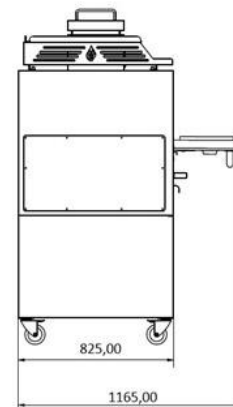

Top view

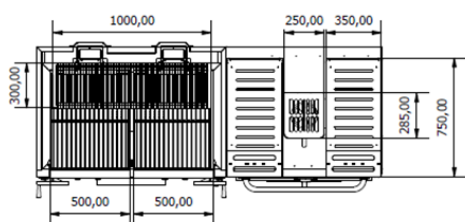

Roasting area Oven

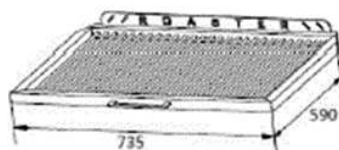

Roasting area Parrilla

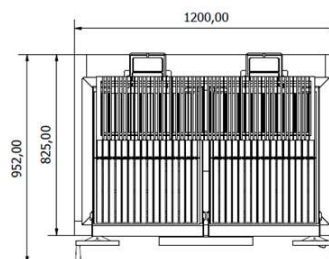

**MAIN COMPONENTS**

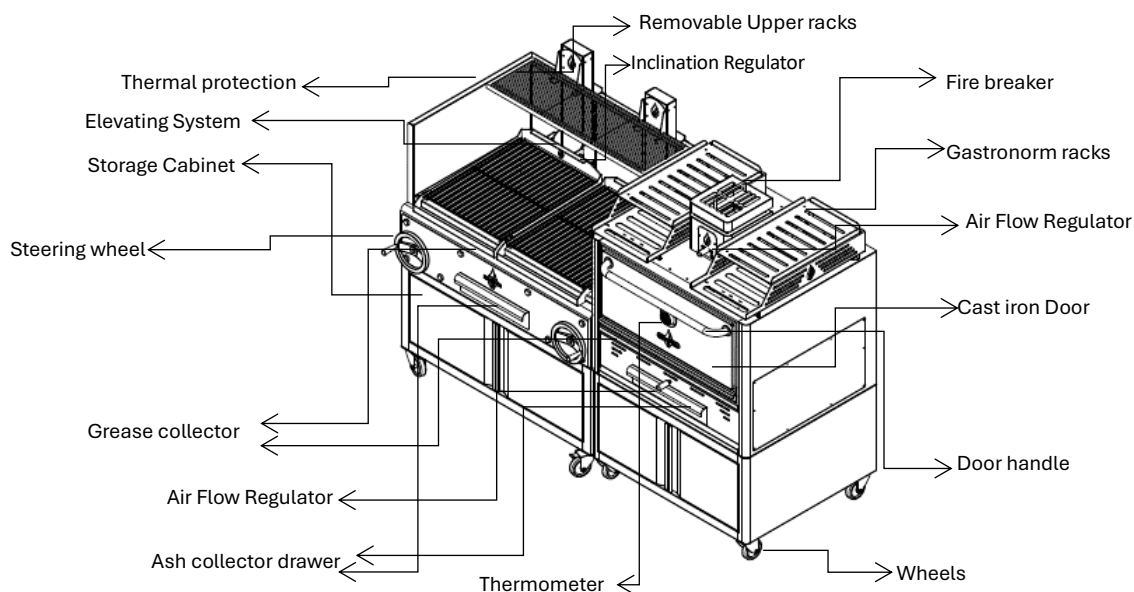

\*Dimensions in mm

\*The charcoal multi is subject to technical and design changes without previous notice

